

*Superior Spa with Aqua-Aire™  
Installation / Assembly Instructions*



**PENNER PATIENT CARE, INC**  
**Box 523 / 101 Grant St.**  
**Aurora, NE 68818**  
350745 Rev G 08-27-14

**1-866-PENNERS**

**1-866-736-6377**

**1-800-732-0717**

***E-mail Address: [pennersales@hamilton.net](mailto:pennersales@hamilton.net)***

**Table of Contents**

Superior Tub Controls ..... 4  
Rough-In Requirements ..... 5  
Unpacking the Superior tub..... 6  
Anchoring the tub ..... 6  
Electrical Connection of the Superior Tub Continued. .... 8  
Plumbing Requirements ..... 8  
Finishing up:..... 9

## Introduction:

These instructions are for the installation of a Superior Aqua-Aire Tub.

### Terminology and Symbols Meanings:

When the terms “left” or “right” are used with reference to the tub, this means left or right as you look at the control panel from the seat end of the tub.



Meaning: Safety warning. Failure to understand and obey this warning may result in injury to you or to others.

**CAUTION**

Meaning: Failure to follow these instructions may cause damage to parts or systems.

NOTE

Meaning: This is important information for proper use of this system or equipment.

## Superior Tub Controls

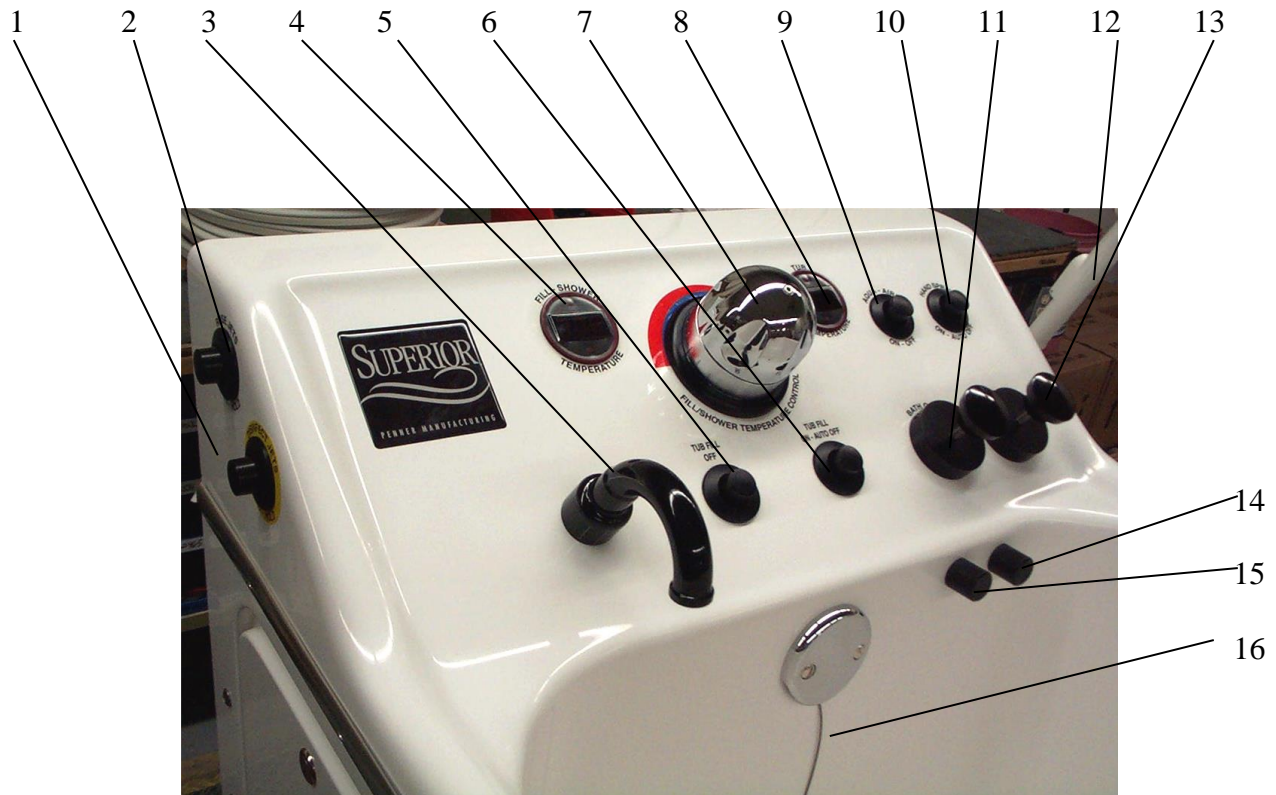

1. Disinfect Button
2. Rinse Button
3. Filling Spout
4. Fill / Shower Water-Temperature Readout
5. Tub Fill OFF Button
6. Tub Fill ON button (The unit has an adjustable time automatic shut-off.)
7. Temperature Control Knob
8. Tub Water-Temperature Readout
9. Aqua-Air ON / OFF Button
10. Shower ON / Auto OFF Button (The unit has an adjustable time automatic shut-off.)
11. Bath Oil Pump Plunger
12. Hand-Held Shower Sprayer
13. Shampoo Pump Plunger
14. Bath Oil Dispensing Spout
15. Shampoo Dispensing Spout
16. Drain Plug Cable

# Rough-In Requirements

Drain requirements: **2" drain** – See Fig 1 or 2 for location.

## Hot and cold water supply requirements:

3/4" supply lines with on/off valves with 3/4" NPT female threads. We recommend 3/4" ball valve with 3/4" NPT female ports. Valves supplied by others. See figure 3 or 4 for recommended locations.

For optimum performance, dynamic pressures should be nominally equal.

Maximum static supply pressure: 145 PSI.

Maximum dynamic/maintained supply pressure: 81 PSI.

Maximum supply Hot water temperature: Consult local requirements for maximum allowed supply temperatures. (Not recommended over 120°F)

Note: A floor drain can be used with the water supply coming from the floor and a wall drain can be used with the water supply coming from the wall.

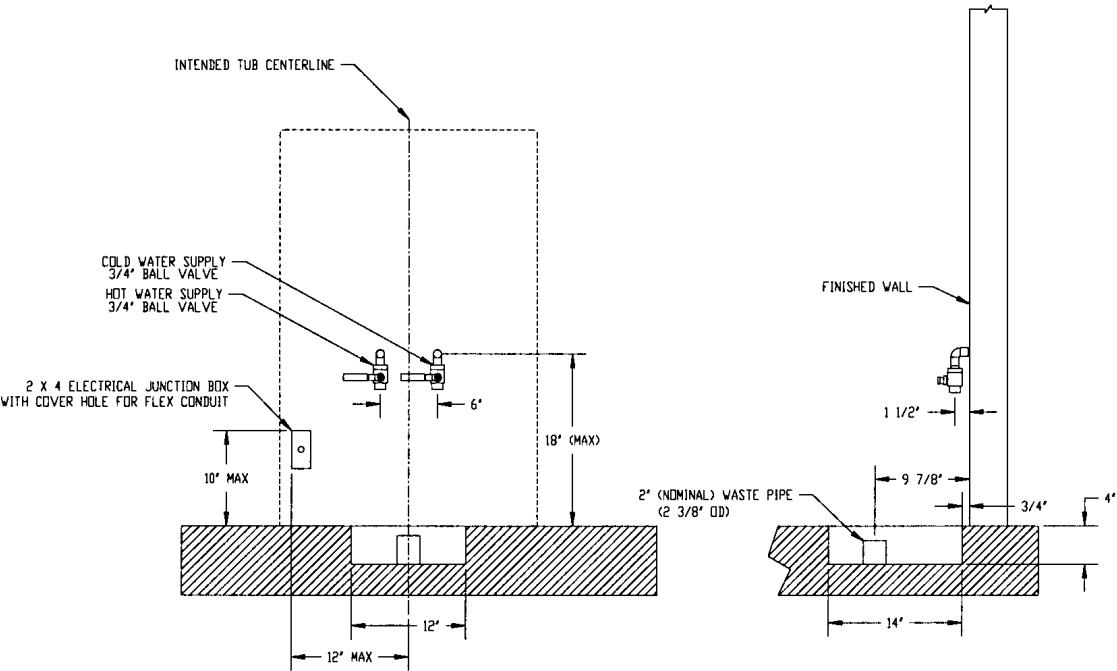

**Fig 1**  
**Rough-in with water supply from the wall and floor drain.**

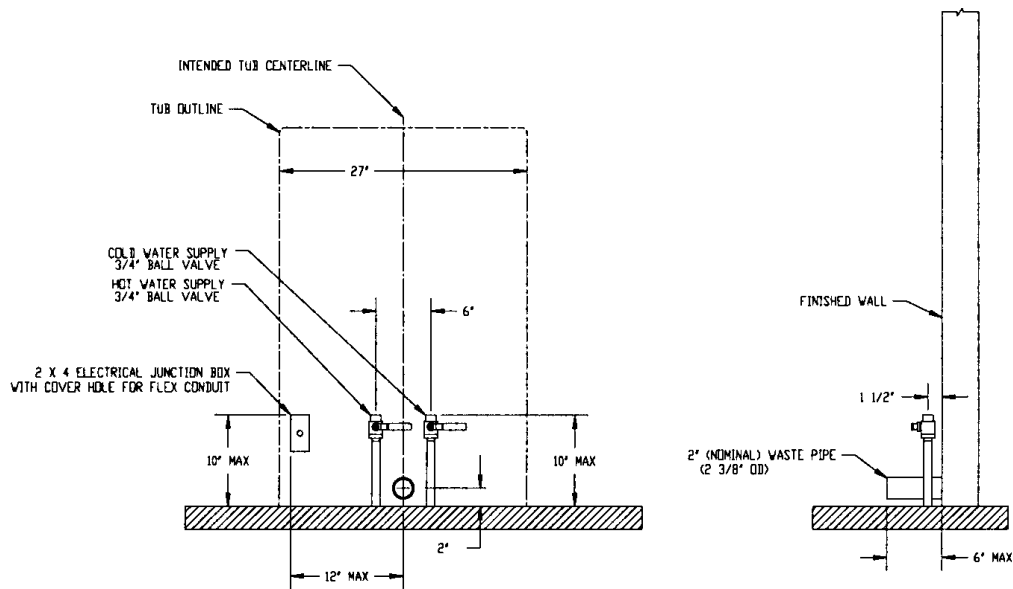

**Fig 2**  
**Rough-in with water supply coming from the floor and wall drain.**

**Electrical requirements:**

Codes in most locations require that circuits in “Wet” locations be provided with ground fault protection.

The Aqua-Air tub (rated at 13.3 amps at 120 Volts) a 15 amp GFCI breaker will work. See **Fig 5** for location of field wiring connection point.

**Unpacking the Superior tub**

1. Remove the tub from the box or crate.

**Anchoring the tub**

These instructions for anchoring the tub are written with the assumption that the installation is being done on a concrete floor. If this is not the case, the tub can be anchored with simple lag screws (not provided). There are three anchoring holes for anchoring the tub. See **figure 3**.

2. Position the tub in the intended installed location.
3. Mark the anchor hole locations on the floor. See figure 3.
4. Remove the tub and drill three 5/16” diameter x 1 1/2 inches deep holes in the

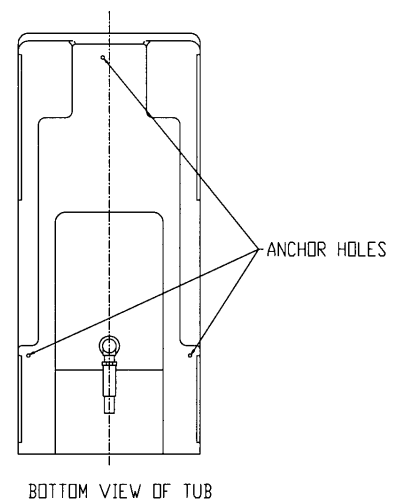

**Figure 3**  
**Tub anchor hole locations**

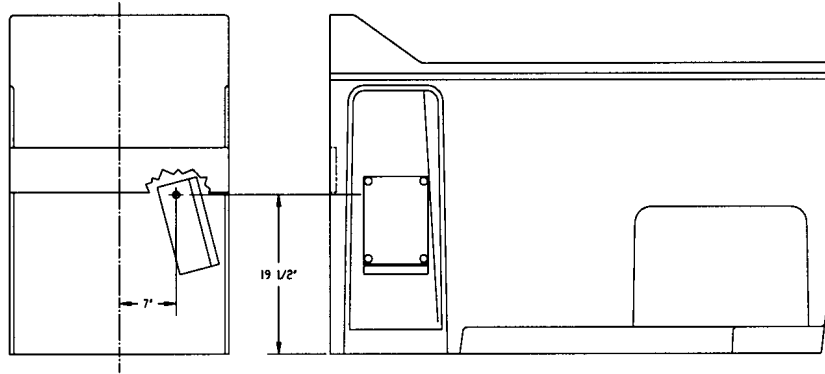

**Fig 4**  
**Electrical Enclosure Location**

floor at the marked locations. A masonry drill will be required.

5. Clean the drilled holes and tap the provided anchor studs into the holes. Ensure that you do not tap the studs in too deep.
6. Remove anchor nuts and washers.
7. Place the tub back into position, over the anchors. This may require more than one person.
8. Replace washers and nuts onto the anchor stud and tighten down.



**This unit is to be connected only by a licensed electrician.**

The Aqua-Air tub is rated at 13.3 amps at 120 volts. So a minimum of 15 amp GFCI circuit is required.

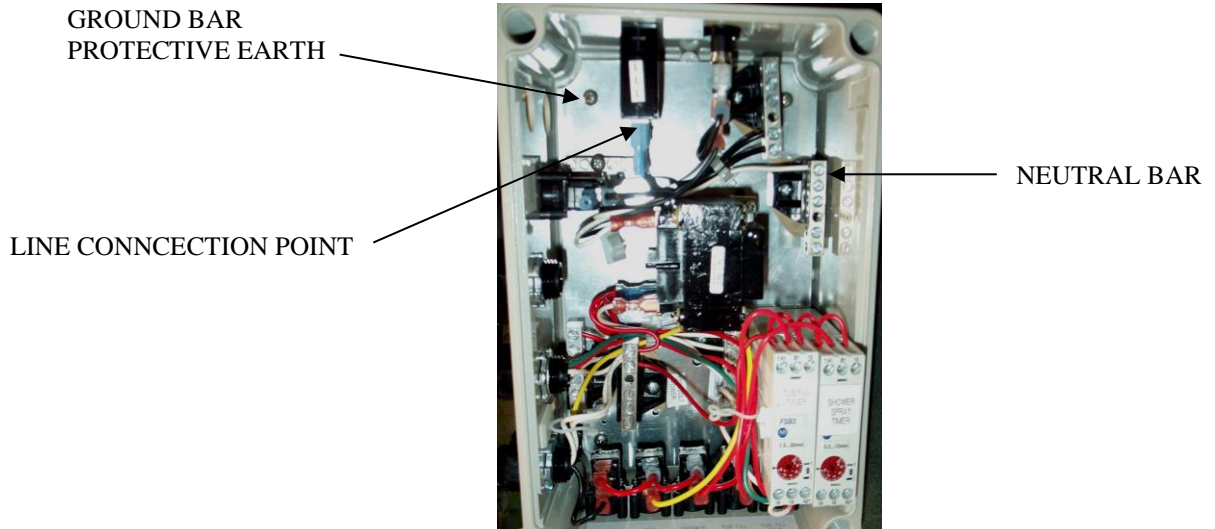

**Fig 5**

## Electrical Kit

### Electrical Connection of the Superior Tub Continued.

9. Remove the tall door on the left side of the tub. Remove the cover of the electrical enclosure. Inside will be a female disconnect terminal connected to the circuit breaker at the locations labeled “L”. This is to be used for making the field connection to the circuit breaker. The neutral wire is to be connected to the neutral bar labeled “N”. The “protective earth” (ground) block is also labeled. **See figure 5.**
10. Find the facility’s electrical junction box meant for powering the tub. Remove the cover and check that there is no power to this circuit.
11. Run flexible conduit and the proper size wires, from the facility’s junction box to the connecting point of the tubs electrical enclosure. **See figure 5.**
12. Connect the ground to the “protective earth” (ground) block.
13. Use the provided female disconnect wire terminals to connect the “line” wire to the circuit breaker tab marked “L” and the “neutral” wire to the “neutral bar” marked “N”.
14. Replace the electrical enclosure cover. With the tub’s circuit breaker switch in the “OFF” position, turn “ON” the circuit to the tub.
15. Switch the tub’s circuit breaker to the “ON” position. The temperature gauges should now display a temperature reading.



## Plumbing Requirements

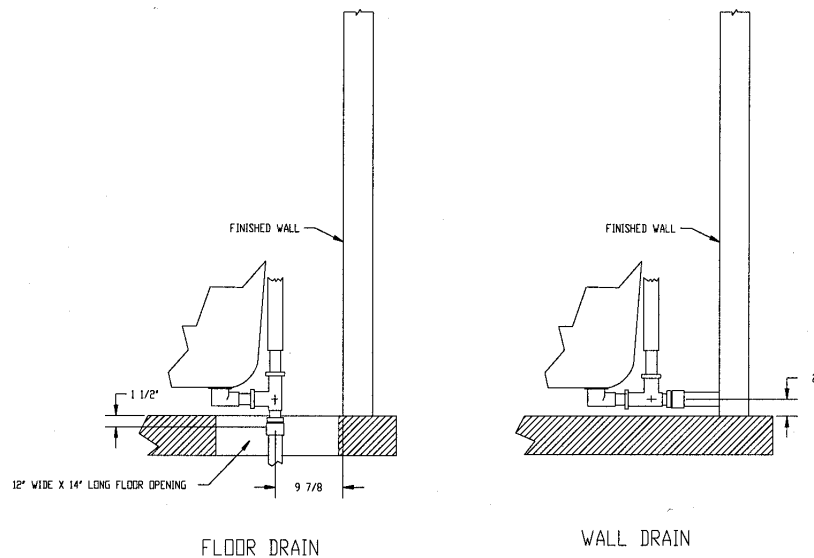

**Fig. 6**  
**Drain connection options.**

**It is required that a licensed plumber make all plumbing connections. He can select the best method of connection and if Reduced Pressure Zone Backflow Preventers are required.**

16. Flexible connecting hoses with stainless steel reinforcement have been provided for connecting the hot and cold water supplies. Connect the rigid end of the connecting hoses to the facility supply valves. Then connect the swivel end to the appropriate tub connections. Be sure to use the sealing washers provided with the hoses.
17. The drain pipe is 2" nominal PVC pipe size (2 3/8" actual outside diameter). It can be connected from the horizontal position or pointed down (vertical position) if connecting to a floor drain pipe. **See fig. 6**
18. Once all the plumbing connections have been made, open the facility's supply valves to the tub and check for leaks. If no leaks are found, check the entire plumbing system for any leaks. Look for leaks while each of the following systems are running: "Tub fill", "Shower", "Rinse", and "Disinfecting".

### Finishing up:

19. Once the tub/reservoir has been connected to the drain, checked for leaks (and fixed if needed), and is connected to power, the access doors can be installed.
20. Train all operators of this equipment before using it per the Safe Operation & Daily Maintenance Instruction Manual.



## **Warning!**

Because this equipment requires a trained operator, and to assure that these benefits are realized, **do not operate** your PMI equipment until an authorized member of your staff has reviewed the Safe Operation & Daily Maintenance Instruction Manual and spoken to your PMI Representative. Failure to acquire this training could result in damage to the equipment or injury to the operator and resident. If needed, Your PMI Products Representative will assist you with questions you may have in the operation of this equipment.

Your Penner Distributor and his personnel are trained to provide in-service instruction and maintenance on your Superior Spa. If you have any questions about the operation or maintenance of your Superior Spa, please contact your Penner Distributor.

For your nearest distributor, contact:

***PENNER PATIENT CARE, INC***  
***Box 523 / 101 Grant St.***  
***Aurora, NE 68818***

**1-866-PENNERS**

**1-866-736-6377**

**1-800-732-0717**

***E-mail Address: [pennersales@hamilton.net](mailto:pennersales@hamilton.net)***  
***Web Site: [www.pennerpatientcare.com](http://www.pennerpatientcare.com)***